

# Rolling bearings — Accessories for sleeve type linear ball bearings

## Part 2: Boundary dimensions and tolerances for series 5

ICS 21.100.20

## National foreword

This British Standard is the UK implementation of ISO 13012-2:2009.

The UK participation in its preparation was entrusted to Technical Committee MCE/7, Rolling bearings.

A list of organizations represented on this committee can be obtained on request to its secretary.

This publication does not purport to include all the necessary provisions of a contract. Users are responsible for its correct application.

**Compliance with a British Standard cannot confer immunity from legal obligations.**

This British Standard was published under the authority of the Standards Policy and Strategy Committee on 31 August 2009

© BSI 2009

ISBN 978 0 580 59015 3

### Amendments/corrigenda issued since publication

Date	Comments

---

---

**Rolling bearings — Accessories for  
sleeve type linear ball bearings —**

Part 2:

**Boundary dimensions and tolerances for  
series 5**

*Roulements — Accessoires pour douilles à billes linéaires —*

*Partie 2: Dimensions d'encombrement et tolérances pour la série 5*



**PDF disclaimer**

This PDF file may contain embedded typefaces. In accordance with Adobe's licensing policy, this file may be printed or viewed but shall not be edited unless the typefaces which are embedded are licensed to and installed on the computer performing the editing. In downloading this file, parties accept therein the responsibility of not infringing Adobe's licensing policy. The ISO Central Secretariat accepts no liability in this area.

Adobe is a trademark of Adobe Systems Incorporated.

Details of the software products used to create this PDF file can be found in the General Info relative to the file; the PDF-creation parameters were optimized for printing. Every care has been taken to ensure that the file is suitable for use by ISO member bodies. In the unlikely event that a problem relating to it is found, please inform the Central Secretariat at the address given below.



**COPYRIGHT PROTECTED DOCUMENT**

© ISO 2009

All rights reserved. Unless otherwise specified, no part of this publication may be reproduced or utilized in any form or by any means, electronic or mechanical, including photocopying and microfilm, without permission in writing from either ISO at the address below or ISO's member body in the country of the requester.

ISO copyright office  
Case postale 56 • CH-1211 Geneva 20  
Tel. + 41 22 749 01 11  
Fax + 41 22 749 09 47  
E-mail [copyright@iso.org](mailto:copyright@iso.org)  
Web [www.iso.org](http://www.iso.org)

Published in Switzerland

## Contents

Page

Foreword.....	iv
Introduction .....	v
1 Scope .....	1
2 Normative references .....	1
3 Terms and definitions.....	2
4 Symbols .....	3
4.1 Closed and adjustable flangeless housings for series 5 sleeve type linear ball bearings .....	3
4.2 Open and open adjustable flangeless housings for series 5 sleeve type linear ball bearings .....	3
4.3 Standard height shaft support rails for series 5 sleeve type linear ball bearings .....	4
4.4 Flanged shaft support blocks for series 5 sleeve type linear ball bearings .....	4
4.5 Solid and tubular shafts for series 5 sleeve type linear ball bearings .....	4
5 Housings.....	5
5.1 General.....	5
5.2 Housings for series 5 sleeve type linear ball bearings.....	5
6 Shaft support rails .....	5
7 Shaft support blocks .....	5
8 Shafts .....	5
8.1 Material .....	5
8.2 Heat treatment.....	5
8.3 Geometrical tolerances .....	6
9 Boundary dimensions and tolerances.....	6
9.1 Housings.....	6
9.2 Shaft support rails .....	9
9.3 Shaft support blocks .....	10
9.4 Shafts .....	11

## Foreword

ISO (the International Organization for Standardization) is a worldwide federation of national standards bodies (ISO member bodies). The work of preparing International Standards is normally carried out through ISO technical committees. Each member body interested in a subject for which a technical committee has been established has the right to be represented on that committee. International organizations, governmental and non-governmental, in liaison with ISO, also take part in the work. ISO collaborates closely with the International Electrotechnical Commission (IEC) on all matters of electrotechnical standardization.

International Standards are drafted in accordance with the rules given in the ISO/IEC Directives, Part 2.

The main task of technical committees is to prepare International Standards. Draft International Standards adopted by the technical committees are circulated to the member bodies for voting. Publication as an International Standard requires approval by at least 75 % of the member bodies casting a vote.

Attention is drawn to the possibility that some of the elements of this document may be the subject of patent rights. ISO shall not be held responsible for identifying any or all such patent rights.

ISO 13012-2 was prepared by Technical Committee ISO/TC 4, *Rolling bearings*, Subcommittee SC 11, *Linear motion rolling bearings*.

ISO 13012 consists of the following parts, under the general title *Rolling bearings — Accessories for sleeve type linear ball bearings*:

- *Part 1: Boundary dimensions and tolerances for series 1 and 3*
- *Part 2: Boundary dimensions and tolerances for series 5*

## **Introduction**

The use of sleeve type linear ball bearings can be facilitated by the selection of bearing housings, shafts, shaft support blocks and shaft support rails. These items, referred to as accessories, can aid in the application of the sleeve type linear ball bearings to achieve the desired criteria of smooth, accurate, low-friction linear motion free from chatter or stick-slip.

The appropriate selection of bearing housing type, shaft and shaft support should be established between the manufacturer and the user.

This part of ISO 13012 was developed to be used with ISO 10285.





# Rolling bearings — Accessories for sleeve type linear ball bearings —

## Part 2: Boundary dimensions and tolerances for series 5

### 1 Scope

This part of ISO 13012 specifies the boundary dimensions, other relevant dimensions and their tolerances of accessories for sleeve type linear ball bearings which are specified in ISO 10285.

This part of ISO 13012 applies to:

housings —

closed and adjustable flangeless housings for series 5 sleeve type linear ball bearings,

open and open adjustable flangeless housings for series 5 sleeve type linear ball bearings;

shaft support rails —

standard height shaft support rails for series 5 sleeve type linear ball bearings;

shaft support blocks —

flanged shaft support blocks for series 5 sleeve type linear ball bearings;

shafts —

solid and tubular shafts for series 5 sleeve type linear ball bearings.

### 2 Normative references

The following referenced documents are indispensable for the application of this document. For dated references, only the edition cited applies. For undated references, the latest edition of the referenced document (including any amendments) applies.

ISO 286-2, *ISO system of limits and fits — Part 2: Tables of standard tolerance grades and limit deviations for holes and shafts*

ISO 1132-1, *Rolling bearings — Tolerances — Part 1: Terms and definitions*

ISO 1302, *Geometrical Product Specifications (GPS) — Indications of surface texture in technical product documentation*

ISO 3754, *Steel — Determination of effective depth of hardening after flame or induction hardening*

ISO 5593, *Rolling bearings — Vocabulary*

ISO 10285:2007, *Rolling bearings — Sleeve type linear ball bearings — Boundary dimensions and tolerances*

ISO 15241, *Rolling bearings — Symbols for quantities*

ISO 24393, *Rolling bearings — Linear motion rolling bearings — Vocabulary*

### 3 Terms and definitions

For the purposes of this document, the terms and definitions given in ISO 1132-1, ISO 5593, ISO 10285, and ISO 24393 apply.

**3.1 flangeless housing**  
(sleeve type linear ball bearing) bearing housing which has a face with bolt holes or threaded holes for attachment to a support surface nominally parallel to the bearing axis

[ISO 13012-1:2009]

**3.2 closed housing**  
(sleeve type linear ball bearing) bearing housing in which the bearing seating is circumferentially continuous

[ISO 13012-1:2009]

**3.3 adjustable housing**  
(sleeve type linear ball bearing) bearing housing with a longitudinal slit across its bearing seating which facilitates the mechanical adjustment of the bearing seating diameter

[ISO 13012-1:2009]

**3.4 open housing**  
(sleeve type linear ball bearing) bearing housing with a longitudinal section removed to provide clearance over a shaft and support rail unit

[ISO 13012-1:2009]

**3.5 open adjustable housing**  
(sleeve type linear ball bearing) bearing housing which has the features of both open and adjustable sleeve type linear ball bearing housings

[ISO 13012-1:2009]

**3.6 shaft support rail**  
longitudinal pedestal which provides continuous support to a shaft

NOTE Shaft support rails may be used with open sleeve type linear ball bearings.

[ISO 13012-1:2009]

**3.7 shaft support block**  
block which provides support to a shaft

NOTE Shaft support blocks are normally used to support the shaft at its ends and can be used with closed sleeve type, adjustable sleeve type or open sleeve type linear ball bearings.

[ISO 13012-1:2009]

**3.8 shaft**  
basically cylindrical rod along which a linear ball bearing traverses

[ISO 13012-1:2009]

## 4 Symbols

For the purposes of this document, the symbols given in ISO 15241 and the following apply.

The symbols (except those for tolerances) shown in Figures 1 to 5, and the values given in Tables 1 to 6 denote nominal dimensions unless specified otherwise.

NOTE Figures 1 to 5 are drawn schematically and do not necessarily show all design details.

### 4.1 Closed and adjustable flangeless housings for series 5 sleeve type linear ball bearings

See Table 1 and Figure 1.

$A$	(overall) width
$D_a$	seating diameter
$F_w$	bore diameter of ball complement of sleeve type linear ball bearing (reference)
$G$	designation of screw thread of attachment hole
$H$	distance from mounting face to centreline of seating diameter
$H_1$	(overall) height
$J$	centre distance between bolt holes (length)
$J_1$	centre distance between bolt holes (width)
$L$	length of housing
$L_1$	distance from side face to centreline of seating diameter
$N$	diameter of bolt hole

### 4.2 Open and open adjustable flangeless housings for series 5 sleeve type linear ball bearings

See Table 2 and Figure 2.

$A$	(overall) width
$D_a$	seating diameter
$E$	width of sector opening (at diameter $D_a$ )
$F_w$	bore diameter of ball complement of sleeve type linear ball bearing (reference)
$G$	designation of screw thread of attachment hole
$H$	distance from mounting face to centreline of seating diameter
$H_1$	(overall) height
$J$	centre distance between bolt holes (length)
$J_1$	centre distance between bolt holes (width)
$L$	length of housing
$L_1$	distance from side face to centreline of seating diameter
$\alpha$	angle of sector opening

### 4.3 Standard height shaft support rails for series 5 sleeve type linear ball bearings

See Table 3 and Figure 3.

$A$	(overall) width
$d$	outside diameter of shaft (reference)
$H$	distance from mounting face to centreline of shaft
$H_1$	height of flange
$J$	centre distance between bolt holes (length)
$J_1$	centre distance between bolt holes (width)
$M$	width of shaft support
$N$	diameter of bolt hole
$N_1$	diameter of bolt hole (shaft attachment)
$\beta$	angle of shaft support

### 4.4 Flanged shaft support blocks for series 5 sleeve type linear ball bearings

See Table 4 and Figure 4.

$A$	(overall) width
$D_a$	seating diameter
$H$	distance from mounting face to centreline of seating diameter
$H_1$	height of flange
$H_2$	(overall) height
$J$	centre distance between bolt holes (length)
$L$	length of base
$N$	diameter of bolt hole

### 4.5 Solid and tubular shafts for series 5 sleeve type linear ball bearings

See Tables 5 and 6, and Figure 5

$d$	outside diameter of shaft
$d_s$	single outside diameter of shaft
$L$	length of shaft
$L_s$	actual length of shaft
$t$	straightness of shaft
$V_{dmp}$	variation of mean outside diameter of shaft
$V_{dsp}$	variation of outside diameter of shaft in a single plane
$\Delta_{ds}$	deviation of a single outside diameter of shaft
$\Delta_{Ls}$	deviation of the actual length of shaft

## 5 Housings

### 5.1 General

To facilitate the design and assembly of sleeve type linear ball bearings, specifically designed housings are available. Included in this part of ISO 13012 are the boundary dimensions and other related dimensions of sleeve type linear ball bearings series 5 as specified in ISO 10285:2007.

The housings specified in Tables 1 and 2, and the corresponding sleeve type linear ball bearings should be supplied by the same producer. The reason for this is that the fixation of the bearings in the housings is specified by the producer and is not covered by this part of ISO 13012.

### 5.2 Housings for series 5 sleeve type linear ball bearings

This part of ISO 13012 includes the following housing designs for series 5 linear ball bearings:

- closed and adjustable flangeless housings for series 5 sleeve type linear ball bearings (Table 1);
- open and open adjustable flangeless housings for series 5 sleeve type linear ball bearings (Table 2).

## 6 Shaft support rails

This part of ISO 13012 includes the following shaft support rails for sleeve type linear ball bearings:

- standard height shaft support rails for series 5 sleeve type linear ball bearings (Table 3).

## 7 Shaft support blocks

This part of ISO 13012 includes the following shaft support blocks for sleeve type linear ball bearings:

- flanged shaft support blocks for series 5 sleeve type linear ball bearings (Table 4).

## 8 Shafts

### 8.1 Material

Shafts covered by this part of ISO 13012 are precision hardened and ground steel shafts in both solid and tubular section. They are manufactured from high quality carbon steel or high quality carbon chrome steel and are either surface hardened or through hardened.

### 8.2 Heat treatment

#### 8.2.1 Surface hardened shafts

The cylindrical surface of the shafts is heat treated to provide a basically uniform effective depth of hardening and a surface hardness of not less than 653 HV (58 HRC) over the entire operating length. The effective depth of hardening shall be determined in accordance with ISO 3754. This effective depth of hardening is the distance from the outside surface of the shaft to a material layer at which the hardness is approximately 80 % of the specified minimum surface hardness. End faces of shafts may remain unhardened.

### 8.2.2 Through hardened shafts

The shafts shall be heat treated to give a surface hardness of no less than 653 HV (58 HRC) over the entire operating length.

## 8.3 Geometrical tolerances

### 8.3.1 Tolerance class

The precision hardened and ground solid and tubular shafts are specified in one diameter tolerance class to match the sleeve type linear ball bearing and housing series 5.

### 8.3.2 Geometric form

The geometric form of the tolerance class is controlled by the following features:

- a) circularity (roundness): variation of shaft outside diameter in a single plane;
- b) cylindricity (taper, concavity, convexity): variation of mean shaft outside diameter;
- c) straightness (per metre).

These tolerances for the class are shown in Table 5. A method for measuring straightness is illustrated in Figure 5 and defined in Table 5.

### 8.3.3 Shaft length tolerances

These tolerances are given in Table 6.

### 8.3.4 Chamfers

The shaft ends are provided with chamfers to facilitate entry of the shaft into the sleeve type linear ball bearing. The ends of shafts with machined end faces are usually provided with chamfers that are shallow in the radial direction and long in the axial direction. The length of the chamfer is shown in Table 5. Shafts for use with sealed sleeve type linear ball bearings shall have a chamfer angle less than 30°.

### 8.3.5 Surface roughness

The roughness of the cylindrical surface of the steel shaft is given in Table 5 in accordance with ISO 1302.

## 9 Boundary dimensions and tolerances

### 9.1 Housings

Boundary dimensions and tolerances for housings are given in Tables 1 and 2.

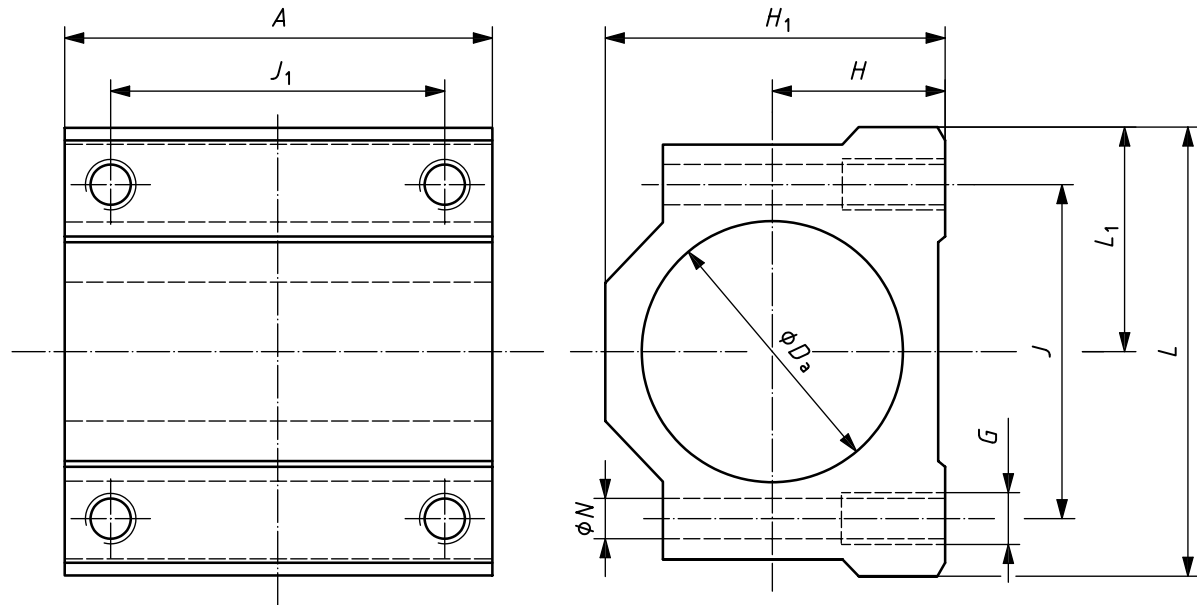

NOTE This figure shows a closed type housing.

**Figure 1 — Closed and adjustable flangeless housings for series 5 sleeve type linear ball bearings**

**Table 1 — Closed and adjustable flangeless housings for series 5 sleeve type linear ball bearings**

Dimensions in millimetres

$F_w$ Ref.	$D_a$ H7 <sup>a</sup>	$H^b$ $\pm 0,02$	$H_1$ max.	$L$ max.	$L_1$ $\pm 0,02$	$J$	Type 1		Type 2		$N$	$G$
							$A$ max.	$J_1$	$A$ max.	$J_1$		
6	12	9	18,5	30	15	20	25	15	48	36	3,4	M4
8	15	11	22,5	34	17	24	30	18	58	42	3,4	M4
10	19	13	26,5	40	20	28	35	21	68	46	4,3	M5
12	21	15	29	42	21	30,5	36	26	70	50	4,3	M5
13	23	15	30,5	44	22	33	39	26	75	50	4,3	M5
16	28	19	39	50	25	36	44	34	85	60	4,3	M5
20	32	21	42	54	27	40	50	40	96	70	5,2	M6
25	40	26	52	76	38	54	67	50	130	100	7	M8
30	45	30	60	78	39	58	72	58	140	110	7	M8
35	52	34	68,5	90	45	70	80	60	155	120	7	M8
40	60	40	78,5	102	51	80	90	60	175	140	8,7	M10
50	80	52	102,5	122	61	100	110	80	215	160	8,7	M10
60	90	58	114,5	132	66	108	122	90	240	180	10,7	M12

NOTE Type 1 housings are designed to be combined with one linear bearing and Type 2 housings are designed to be combined with two linear bearings.

<sup>a</sup> Seating diameter tolerance (see ISO 286-2).

<sup>b</sup> The dimension  $H$  shall be measured with the nominal seating bore diameter. For adjustable type housings the tolerance for  $D_a$  shall apply before the housing is split.

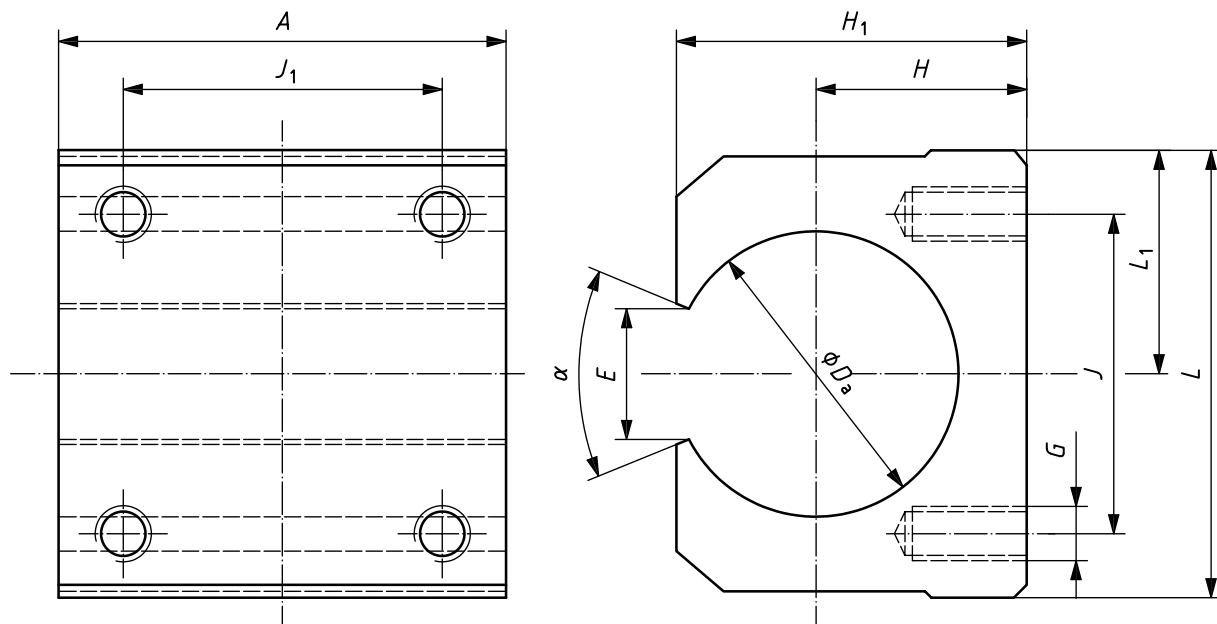

NOTE This figure shows an open type housing.

Figure 2 — Open and open adjustable flangeless housings for series 5 sleeve type linear ball bearings

Table 2 — Open and open adjustable flangeless housings for series 5 sleeve type linear ball bearings

Dimensions in millimetres and angles in degrees

$F_w$ Ref.	$D_a^a$ JS7 <sup>b</sup>	$H^c$ $\pm 0,02$	$H_1$ max.	$L$	$L_1$ $\pm 0,02$	$A$ max.	$J$	$J_1$	$G$	$\alpha$ min.	$E$ min.
13	23	17	28	40	20	39	28	26	M5	80	14,8
16	28	20	34	45	22,5	45	32	30	M5	80	17,7
20	32	23	39	48	24	50	35	35	M6	60	16
25	40	28	48	60	30	65	40	40	M6	50	16,9
30	45	33	56	70	35	70	50	50	M8	50	19
35	52	37	63	80	40	80	55	55	M8	50	22
40	60	42	72	90	45	90	65	65	M10	50	25,4
50	80	53	92	120	60	110	94	80	M10	50	33,8

<sup>a</sup> Diameter  $D_a$  can only be measured when housing is fastened to a plane surface.

<sup>b</sup> Seating diameter tolerance (see ISO 286-2).

<sup>c</sup> The dimension  $H$  shall be measured with the nominal seating bore diameter.



## 9.2 Shaft support rails

Boundary dimensions are given in Table 3.

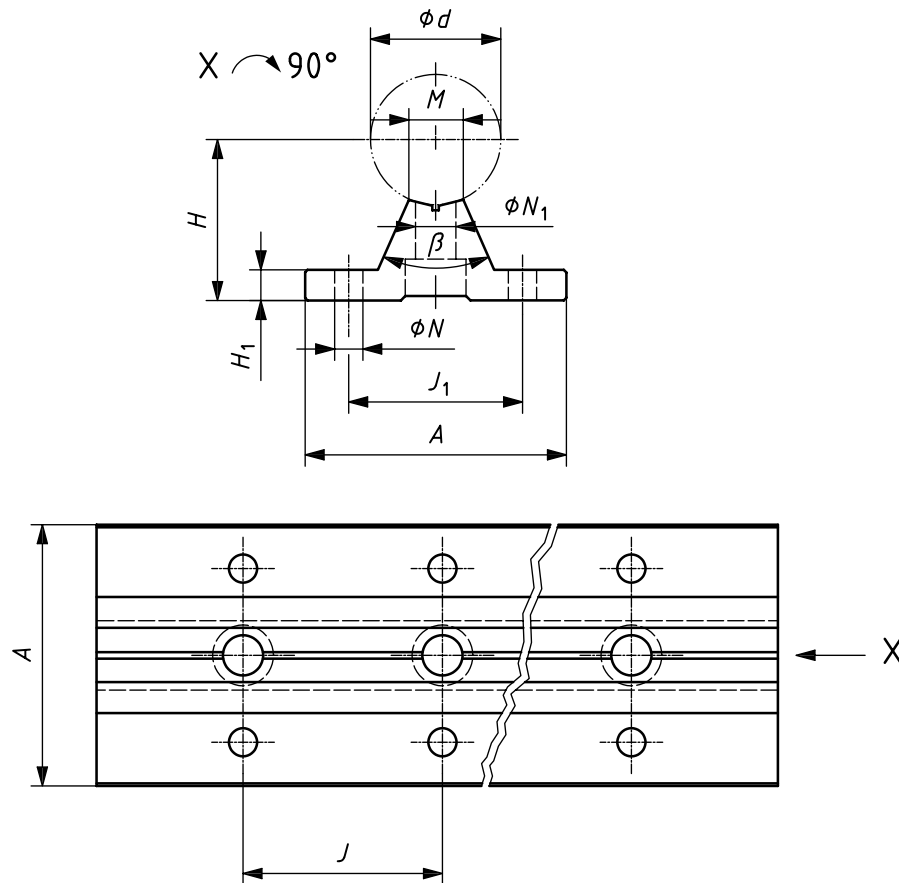

Figure 3 — Standard height shaft support rails for series 5 sleeve type linear ball bearings

Table 3 — Standard height shaft support rails for series 5 sleeve type linear ball bearings

Dimensions in millimetres and angles in degrees

$d$ Ref.	$H^a$ $\pm 0,02$	$A$ max.	$H_1$ $\pm 0,5$	$J_1$	$J$	$M$ max.	$N$	$N_1$	$\beta$ max.
10	18	32	4	22	100	4,7	4,5	4,5	80
13	21	34	4,5	25	100	6,5	4,5	4,5	80
16	25	40	5	30	100	8	5,5	5,5	80
20	27	45	5	30	100	8,5	5,5	6,6	50
25	32	55	6	35	120	10,6	6,6	6,6	50
30	37	60	7	40	150	12,7	6,6	9	50
35	43	65	8	45	200	14,8	9	9	50
40	48	75	9	55	300	16,9	9	9	50
50	62	95	11	70	300	20	11	11	50

<sup>a</sup> The dimension  $H$  shall be measured with the nominal shaft diameter under mounting condition.

### 9.3 Shaft support blocks

Boundary dimensions are given in Table 4.

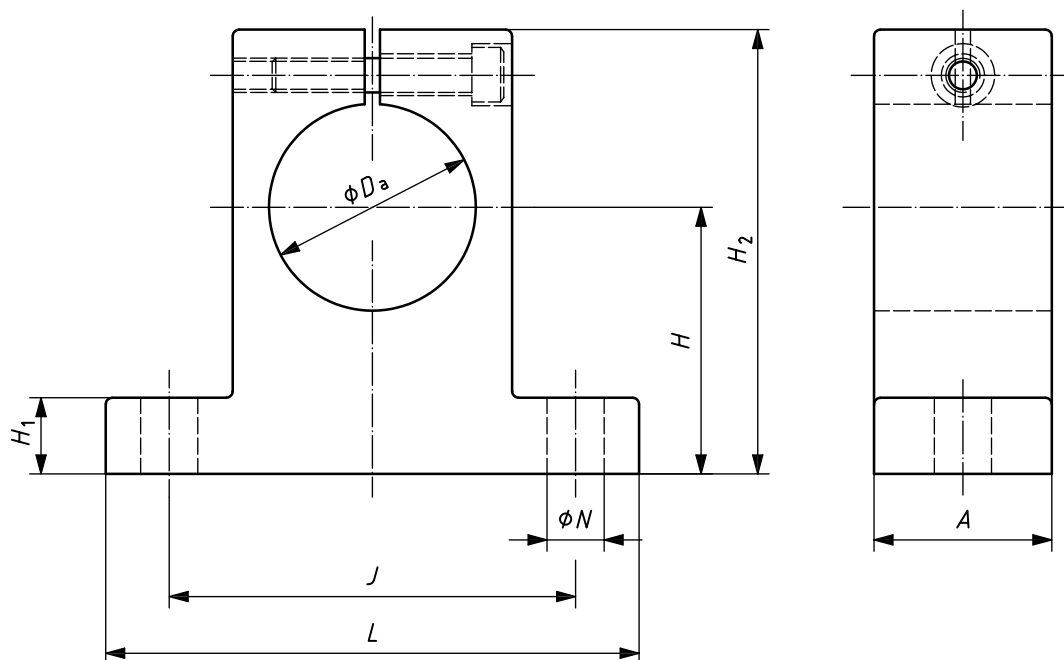

Figure 4 — Flanged shaft support blocks for series 5 sleeve type linear ball bearings

Table 4 — Flanged shaft support blocks for series 5 sleeve type linear ball bearings

Dimensions in millimetres

$D_a$ H8 <sup>a</sup>	$H^b$ $\pm 0,02$	$A$ max.	$J$	$N$	$L$ max.	$H_1$ max.	$H_2$ max.
10	20	14,5	32	5,5	42,5	6,5	33
12	23	14,5	32	5,5	42,5	6,5	38
13	23	14,5	32	5,5	42,5	6,5	38
16	27	16,5	38	5,5	48,5	8,5	44,5
20	31	20,5	45	6,6	60,5	10,5	51,5
25	35	24,5	56	6,6	70,5	12,5	60,5
30	42	28,5	64	9	84,5	12,5	70,5
35	50	33	74	11	100	15,5	87
40	60	37	90	11	120	18	104
50	70	40	100	13,5	140	20	122
60	80	46	120	13,5	165	21	140

<sup>a</sup> Seating diameter tolerance (see ISO 286-2). The tolerance shall apply before the support block is split.

<sup>b</sup> The dimension  $H$  shall be measured with the nominal shaft seating bore diameter.

## 9.4 Shafts

Boundary dimensions and tolerances are given in Tables 5 and 6.

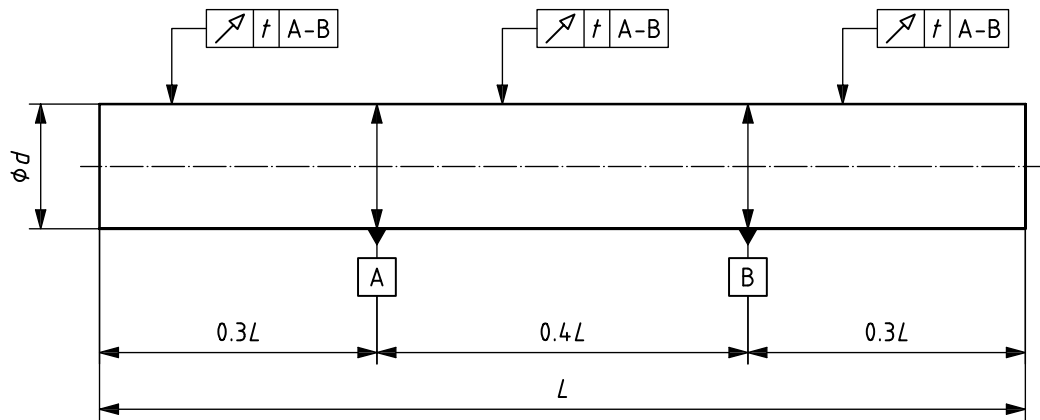

Figure 5 — Solid and tubular shafts for series 5 sleeve type linear ball bearings

Table 5 — Solid and tubular shafts for series 5 sleeve type linear ball bearings

$d$ mm	$\Delta_{ds}$ $\mu\text{m}$		$V_{dsp}$ $\mu\text{m}$ max.	$V_{dmp}$ $\mu\text{m}$ max.	$t$ Straightness <sup>a</sup> $\mu\text{m}/\text{m}$ max.	Surface roughness $R_a$ $\mu\text{m}$ max.	Effective depth of hardening <sup>b</sup> mm min.	Length of chamfer mm min.
	high	low						
3	-8	-14	3	4	150	0,32	0,4	0,8
4	-8	-16	4	5	150	0,32	0,4	0,8
5	-8	-16	4	5	150	0,32	0,4	1
6	-9	-17	4	5	150	0,32	0,4	1
8	-9	-18	4	6	120	0,32	0,4	1
10	-9	-18	4	6	120	0,32	0,4	1
12	-9	-20	5	8	100	0,32	0,6	1,5
13	-9	-20	5	8	100	0,32	0,6	1,5
16	-9	-20	5	8	100	0,32	0,6	1,5
20	-10	-23	6	9	100	0,32	0,9	1,5
25	-10	-23	6	9	100	0,32	0,9	1,5
30	-10	-23	6	9	100	0,32	0,9	1,5
35	-12	-28	7	11	100	0,32	1,5	2,5
40	-12	-28	7	11	100	0,32	1,5	2,5
50	-12	-28	7	11	100	0,32	1,5	2,5
60	-15	-34	8	13	100	0,32	2,2	2,5
80	-15	-34	8	13	100	0,32	2,2	2,5
100	-20	-42	10	15	100	0,32	3,2	3,5

NOTE These shafts are only suitable for use in combination with sleeve type linear ball bearings of series 5 as specified in ISO 10285:2007.

<sup>a</sup> Straightness specifications measured as in Figure 5. Measurements are taken at points equidistant between support points and overhanging end of the shaft. A shaft, when supported as shown and rotated through 360° shall not cause a total indicator reading (TIR) in excess of the straightness tolerance stated above. The TIR values given by this measurement method are double the real shaft straightness tolerance values.

<sup>b</sup> For surface hardened shafts.

**Table 6 — Shaft length tolerances for series 5**

Dimensions and tolerance values in millimetres

<i>L</i>		$\Delta_{L_s}$	
>	$\leq$	high	low
30	120	+0,3	-0,3
120	400	+0,5	-0,5
400	1 000	+0,8	-0,8
1 000	2 000	+1,2	-1,2
2 000	4 000	+2	-2
4 000	8 000	+3	-3







---

## BSI - British Standards Institution

BSI is the independent national body responsible for preparing British Standards. It presents the UK view on standards in Europe and at the international level. It is incorporated by Royal Charter.

### Revisions

British Standards are updated by amendment or revision. Users of British Standards should make sure that they possess the latest amendments or editions.

It is the constant aim of BSI to improve the quality of our products and services. We would be grateful if anyone finding an inaccuracy or ambiguity while using this British Standard would inform the Secretary of the technical committee responsible, the identity of which can be found on the inside front cover. Tel: +44 (0)20 8996 9000. Fax: +44 (0)20 8996 7400.

BSI offers members an individual updating service called PLUS which ensures that subscribers automatically receive the latest editions of standards.

### Buying standards

Orders for all BSI, international and foreign standards publications should be addressed to Customer Services. Tel: +44 (0)20 8996 9001. Fax: +44 (0)20 8996 7001 Email: [orders@bsigroup.com](mailto:orders@bsigroup.com) You may also buy directly using a debit/credit card from the BSI Shop on the Website <http://www.bsigroup.com/shop>

In response to orders for international standards, it is BSI policy to supply the BSI implementation of those that have been published as British Standards, unless otherwise requested.

### Information on standards

BSI provides a wide range of information on national, European and international standards through its Library and its Technical Help to Exporters Service. Various BSI electronic information services are also available which give details on all its products and services. Contact Information Centre. Tel: +44 (0)20 8996 7111 Fax: +44 (0)20 8996 7048 Email: [info@bsigroup.com](mailto:info@bsigroup.com)

Subscribing members of BSI are kept up to date with standards developments and receive substantial discounts on the purchase price of standards. For details of these and other benefits contact Membership Administration. Tel: +44 (0)20 8996 7002 Fax: +44 (0)20 8996 7001 Email: [membership@bsigroup.com](mailto:membership@bsigroup.com)

Information regarding online access to British Standards via British Standards Online can be found at <http://www.bsigroup.com/BSOL>

Further information about BSI is available on the BSI website at <http://www.bsigroup.com>

### Copyright

Copyright subsists in all BSI publications. BSI also holds the copyright, in the UK, of the publications of the international standardization bodies. Except as permitted under the Copyright, Designs and Patents Act 1988 no extract may be reproduced, stored in a retrieval system or transmitted in any form or by any means – electronic, photocopying, recording or otherwise – without prior written permission from BSI.

This does not preclude the free use, in the course of implementing the standard, of necessary details such as symbols, and size, type or grade designations. If these details are to be used for any other purpose than implementation then the prior written permission of BSI must be obtained.

Details and advice can be obtained from the Copyright and Licensing Manager. Tel: +44 (0)20 8996 7070 Email: [copyright@bsigroup.com](mailto:copyright@bsigroup.com)